

Tengzhou Freed Rotary Joint Ltd.

WD Rotary Joint

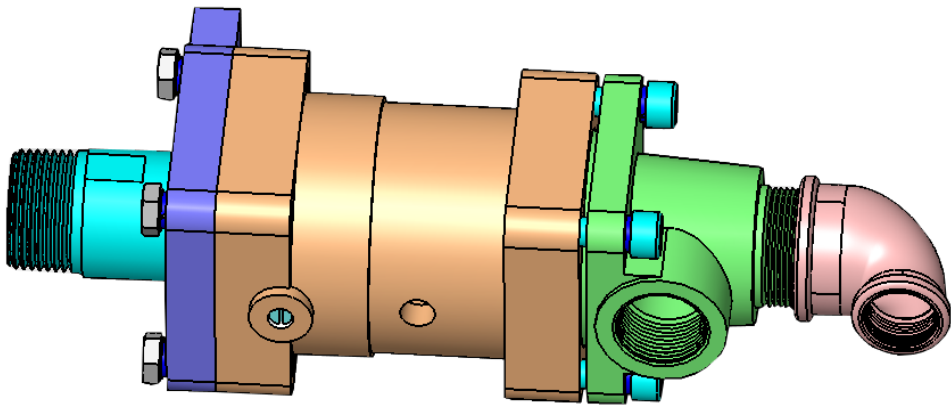

Three-dimensional Drawing of WDSG32-15 Rotary Joint

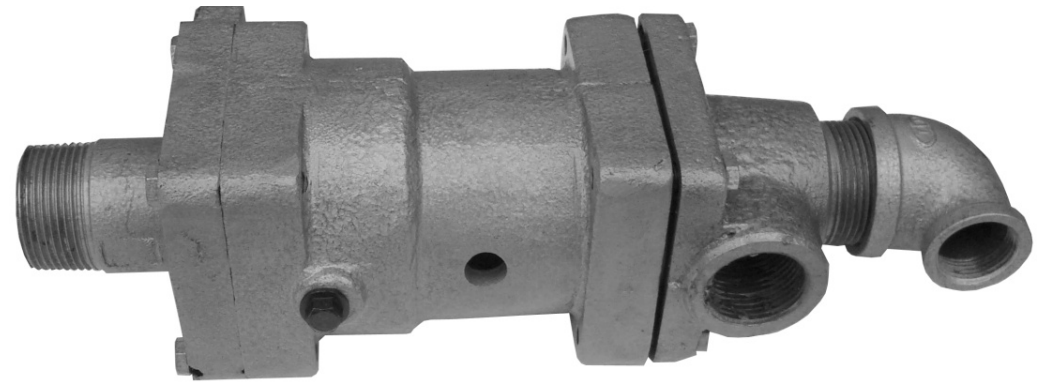

Practicality of WDSG32-15 Rotary Joint

The drawing of WDSG50-25 Rotary Joint

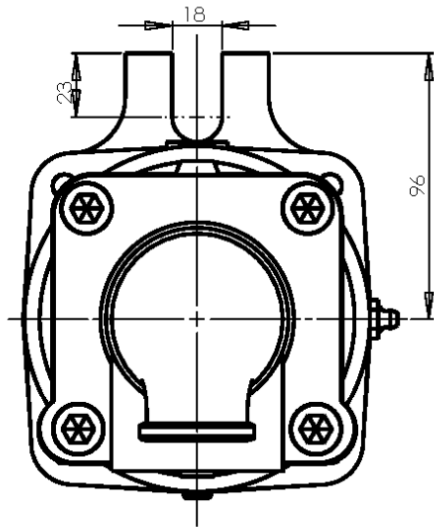

WDSG50-25 Rotary Joint

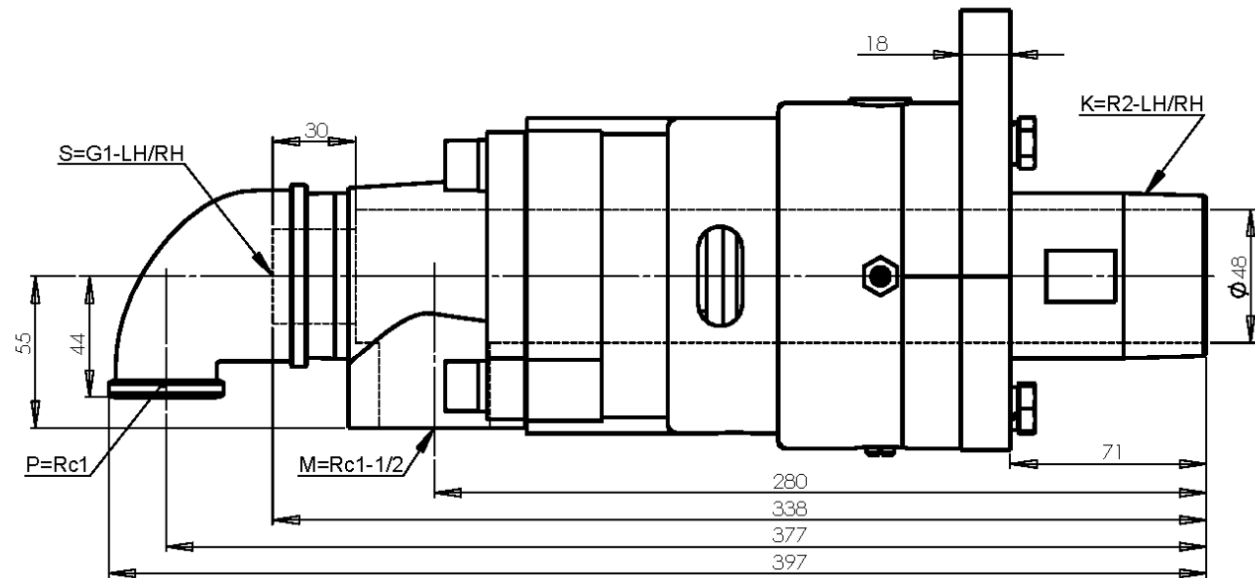

Surface Contour for Dual Flow WDSG50-25 Rotary Joint With Stationary Internal Pipe

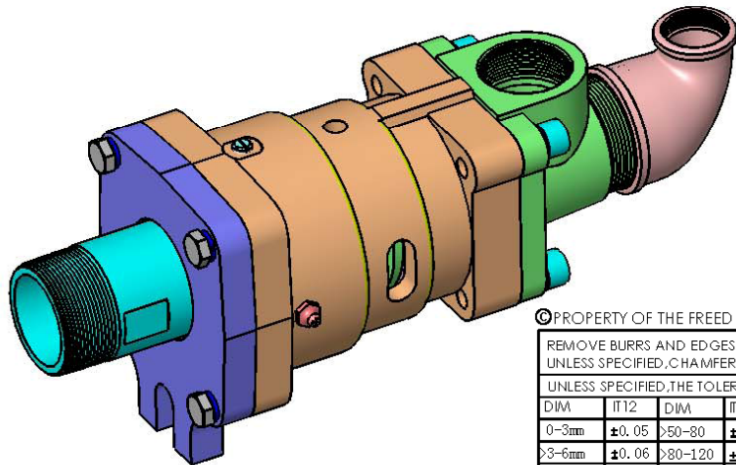

WD Rotary Joint

OPERATING PARAMETER	
MAX. PRESSURE (bar)	35 bar
MAX. TEMPERATURE (°C)	100°C
MAX. SPEED (RPM)	1000 RPM
MEDIA	Steam, Water, oil

©PROPERTY OF THE FREED CORPORATION. THE DRAWING AND ITS INFORMATION ARE CONFIDENTIAL AND MUST BE RETURNED IF REQUESTED BY THE FREED CORPORATION.

REMOVE BURRS AND EDGES. UNLESS SPECIFIED, CHAMFER IS 0.5X45° OR FILLET IS R0.5.						MATERIAL NO.:		REMARKS: .	
UNLESS SPECIFIED, THE TOLERANCE IS IT12.						CHINA MATERIAL: .		THE FREED CORPORATION www.freedseal.com	
USA MATERIAL: .						DRAWN BY: Steven			
DIM	IT12	DIM	IT12	DIM	IT12	CHECKED BY: Frank		DNNNO.: FEDN201201-04	
0-3mm	±0.05	>3-6mm	±0.06	>6-10mm	±0.08	TREATMENT: .		DATE: 2012-1-4	
>3-6mm	±0.06	>6-10mm	±0.08	>10-18mm	±0.09	REF. DWG NO.: SW : 8620509920		PROJECT VIEW	
>6-10mm	±0.08	>10-18mm	±0.09	>18-30mm	±0.11	SYMBLE NUMBER: WDG050992R		NAME: WDSG50-25 ROTARY JOINT	
>10-18mm	±0.09	>18-30mm	±0.11	>30-50mm	±0.13	ITEM NUMBER: 862050992401		SURFACE DRAWING	
>18-30mm	±0.11	>30-50mm	±0.13			SCALE 1:1		CFG: JOINT WDG R-NIPPLE	
>30-50mm	±0.13					PAGE 1 OF 1		DWG NO.: 862050992401	
								REV. A	

The drawing of WDSGF50-25 Rotary Joint

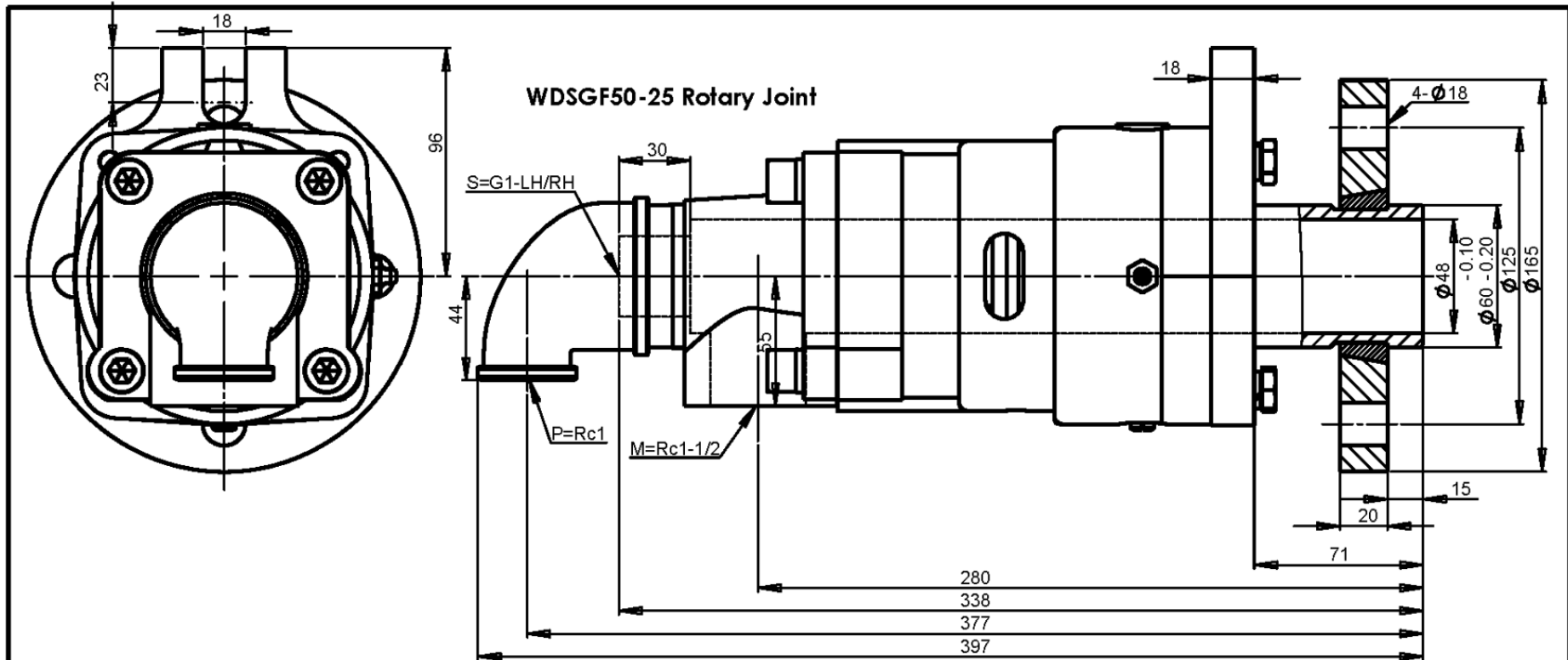

Surface Contour for Dual Flow WDS-GF50-25 Rotary Joint With Stationary Internal Pipe

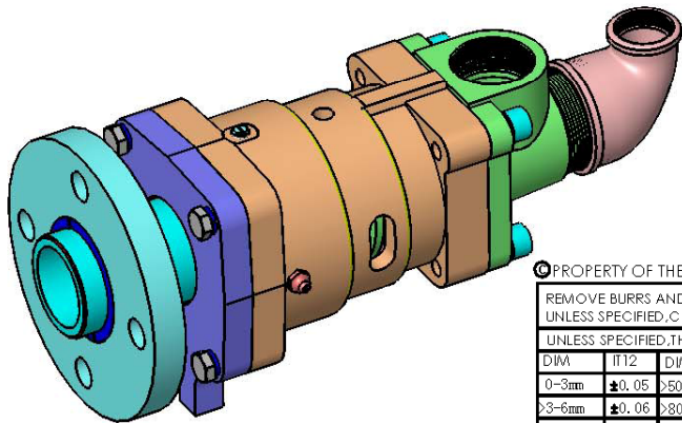

WD Rotary Joint

OPERATING PARAMETER	
MAX. PRESSURE (bar)	35 bar
MAX. TEMPERATURE (°C)	100°C
MAX. SPEED (RPM)	1000 RPM
MEDIA	Steam, Water, oil

© PROPERTY OF THE FREED CORPORATION. THE DRAWING AND ITS INFORMATION ARE CONFIDENTIAL AND MUST BE RETURNED IF REQUESTED BY THE FREED CORPORATION.

REMOVE BURRS AND EDGES.
UNLESS SPECIFIED, CHAMFER IS 0.5X45° OR FILLET IS R0.5.

UNLESS SPECIFIED, THE TOLERANCE IS IT12.

DIM	IT12	DIM	IT12	DIM	IT12
0-3mm	±0.05	>3-6mm	±0.06	>6-10mm	±0.08
>3-6mm	±0.06	>6-10mm	±0.08	>10-18mm	±0.09
>6-10mm	±0.08	>10-18mm	±0.09	>18-30mm	±0.11
>10-18mm	±0.09	>18-30mm	±0.11	>30-50mm	±0.13
>3-6mm	±0.15	>6-10mm	±0.20	>10-18mm	±0.23
>6-10mm	±0.15	>10-18mm	±0.20	>18-30mm	±0.26
>10-18mm	±0.20	>18-30mm	±0.26	>30-50mm	±0.28
>3-6mm	±0.32	>6-10mm	±0.40	>10-18mm	±0.45
>6-10mm	±0.32	>10-18mm	±0.40	>18-30mm	±0.53
>10-18mm	±0.32	>18-30mm	±0.40	>30-50mm	±0.63

MATERIAL NO.:	REMARKS:
CHINA MATERIAL:	
USA MATERIAL:	
DRAWN BY: Steven	DRNO.: FDRNO201201-04
CHECKED BY: Frank	DNNNO.: FEDN201201-04
TREATMENT:	DATE: 2008-9-20
REF. DWG NO.: SW : 860050990	
SYMBLE NUMBER: WDG050992F	
ITEM NUMBER: 862050991501	

THE FREED CORPORATION
www.freedseal.com

PROJECT VIEW	NAME: WDS-GF50-25 ROTARY JOINT
SCALE 1:1	SURFACE DRAWING
A3	CFG: JOINT DG Q-FLANGE
PAGE 1 OF 1	DWG NO.: 862050991501
REV. A	

Contact us

Tengzhou Freed Rotary Joint Ltd.

Address: Qianxin street, Tengzhou city, Shandong province, China.

Tel: 0632-5508518, 5508528

Fax: 0632-5502020

E-mail: freedseal@188.com

Web site: www.freedseal.com